



STAND INFORMATION

LiGH^T25

19 & 20 NOVEMBER 2025 • BUSINESS DESIGN CENTRE • LONDON

lightexpo.london

Stand Information

Shell scheme stands at LiGHT Expo will be constructed from traditional wooden panels and finished in white.

On the following pages you can see examples of the various layout configurations and stand heights across the event.

Please note that the hall is fully carpeted with dark grey carpet tiles.

Additional floorcovering is NOT included in your shell scheme package, this can be ordered as an extra via the exhibitor manual.

Floorcovering optional extra.

General Notes:

1. There is NO access for wiring behind your stand as this will either be a neighbouring stand OR a venue solid wall. Please ensure that all wiring is undertaken on the 'front' of your walling.

2. If any one side of your stand is 4m wide or over there may be an end panel required on your open edge to keep the wall up.

Depending on the configuration of the block you are located on this will be either 0.5m or 1m. We will advise you of this in advance of the event but please speak with the Ops team if you need more information.

IMPORTANT NOTICE - Traditional Panels Recommended fixings methods are:

Screws, pins, nails & staples. For advice on fixings methods please contact the service desk opposite the organiser's office.

Please ensure all fixings are carefully removed from panels at the close of the show. A charge will be applied if fixings are not removed.

We ask that exhibitors please **DO NOT** use the following fixing methods on panels:
Rawl plugs, cavity fixings and adhesive fixings (e.g. Velcro, double sided tape & any type of adhesive including wallpaper paste).

A charge will be applied for any exhibitor; painting stands panels or for any damaged stand panels - if you wish to paint or wallpaper your stand please order painted panels OR MDF overlays via the exhibitor manual.



Village Green and Mezzanine

The following pages pertain to stands within the Village Green and Mezzanine (Shell Scheme stands with stand numbers 1 - 72)

OPEN TWO SIDES

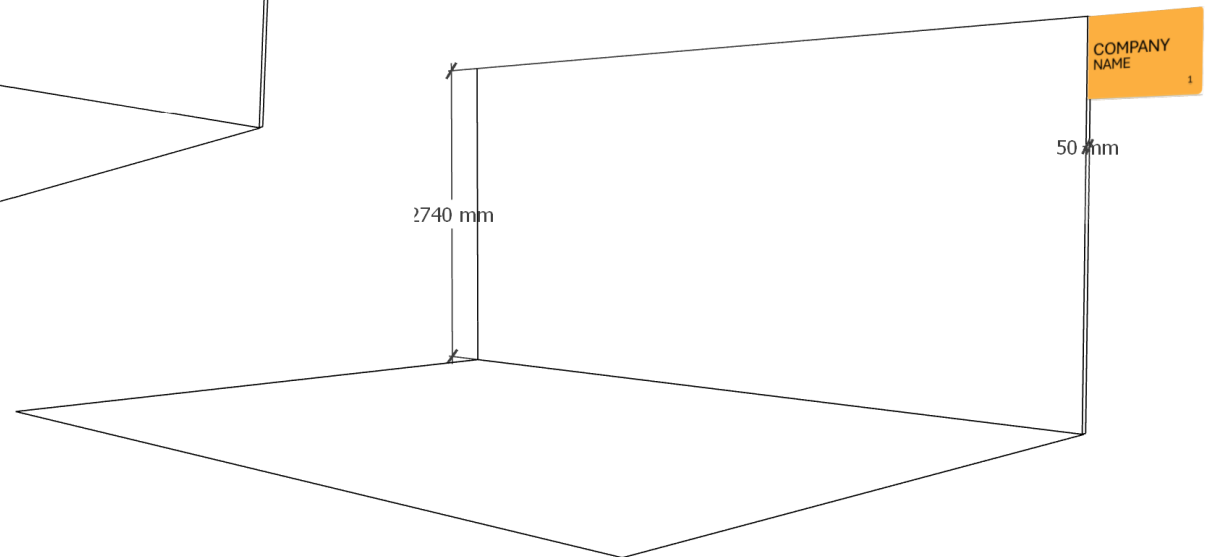
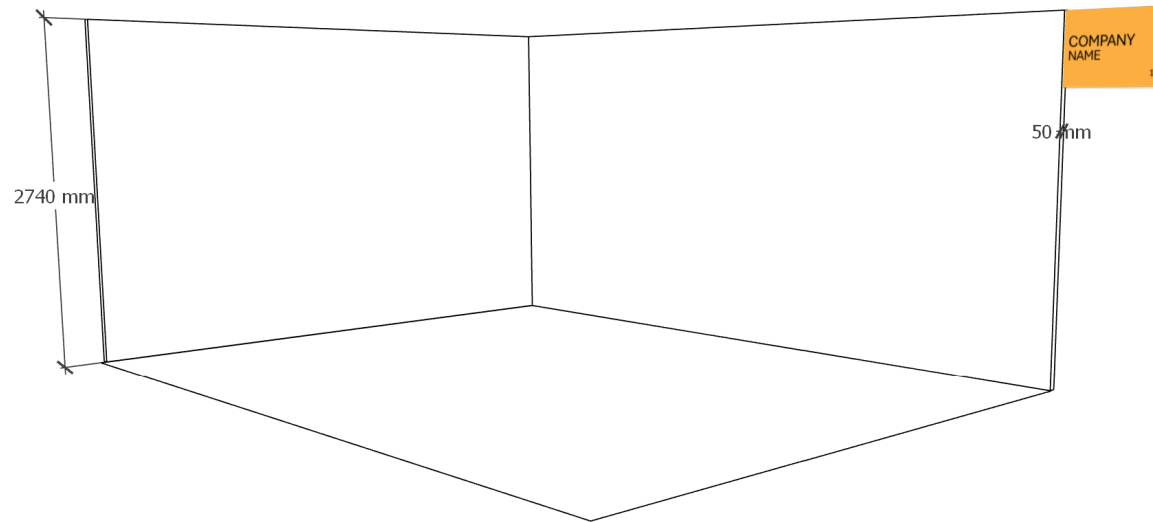

OPEN THREE SIDES

NOTE: Check your contract for your stand dimensions

Perimeter Mezzanine Stands

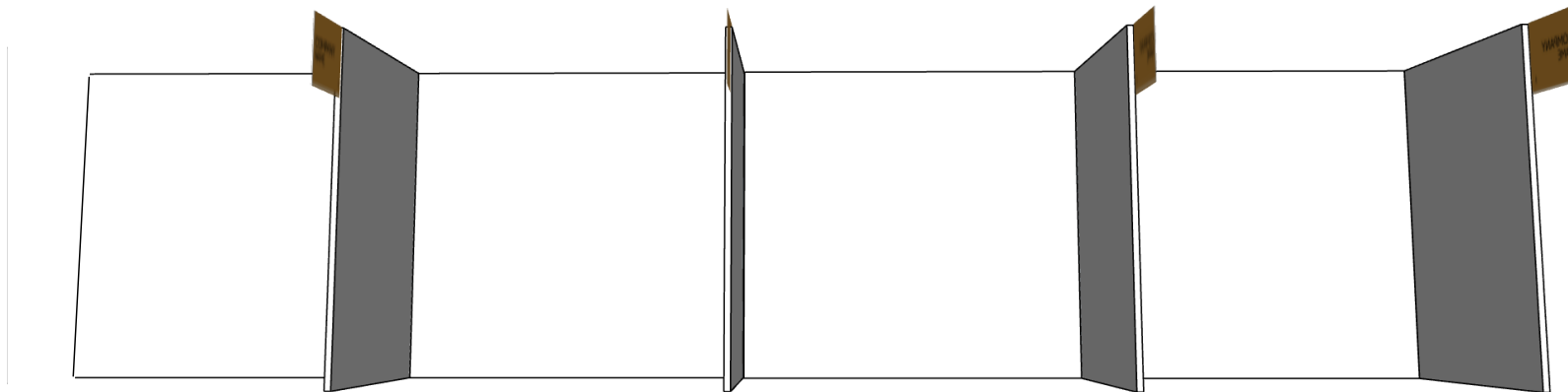
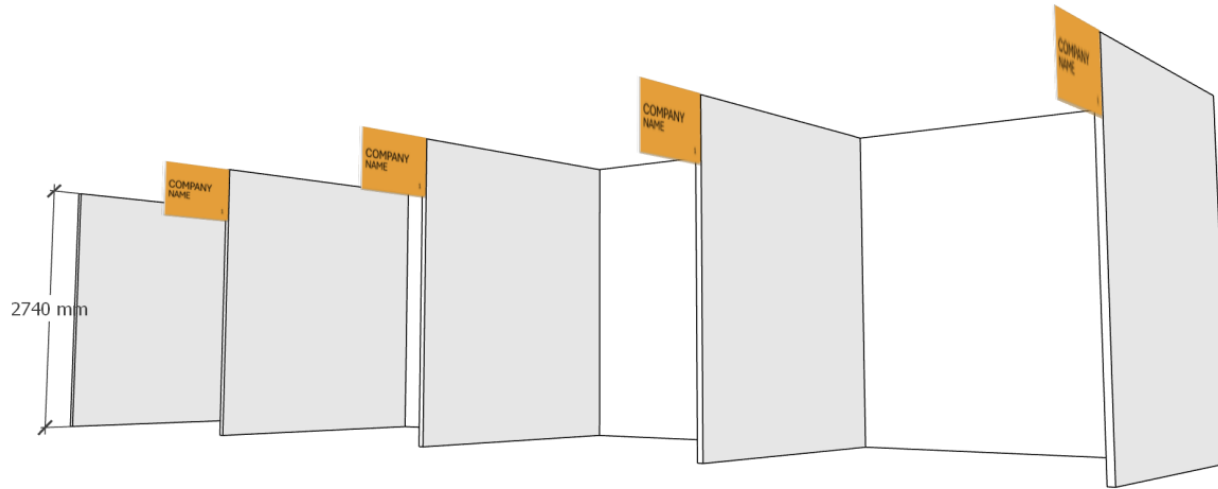

NOTE: Check your contract for your stand dimensions

Gallery Bays

The following pages pertain to stands within the Gallery Bays
(Shell Scheme stands with a 'U' prefix)

FULL BAY

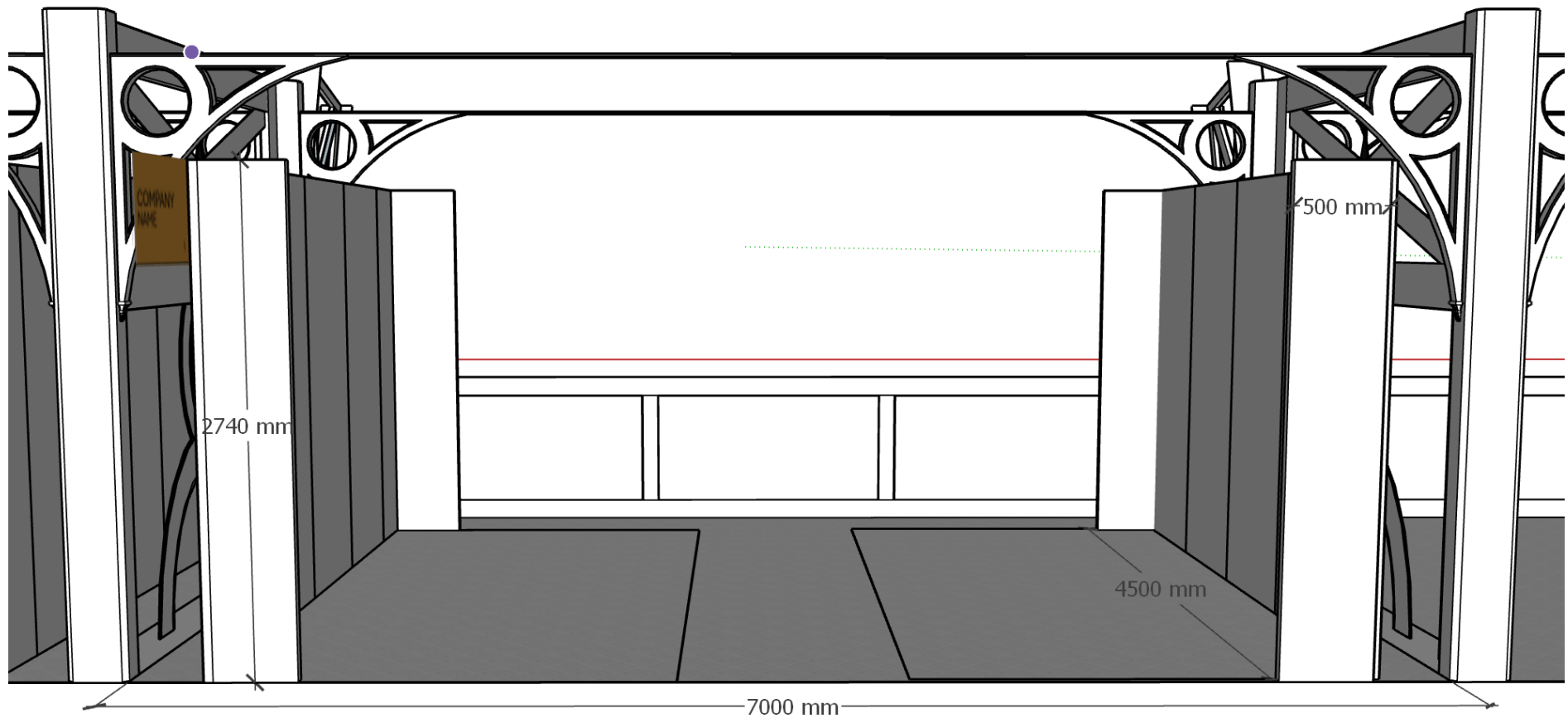

NOTE: Check your contract for your stand dimensions

Gallery Bays

The following pages pertain to stands within the Gallery Bays
(Shell Scheme stands with a 'U' prefix)

HALF BAY

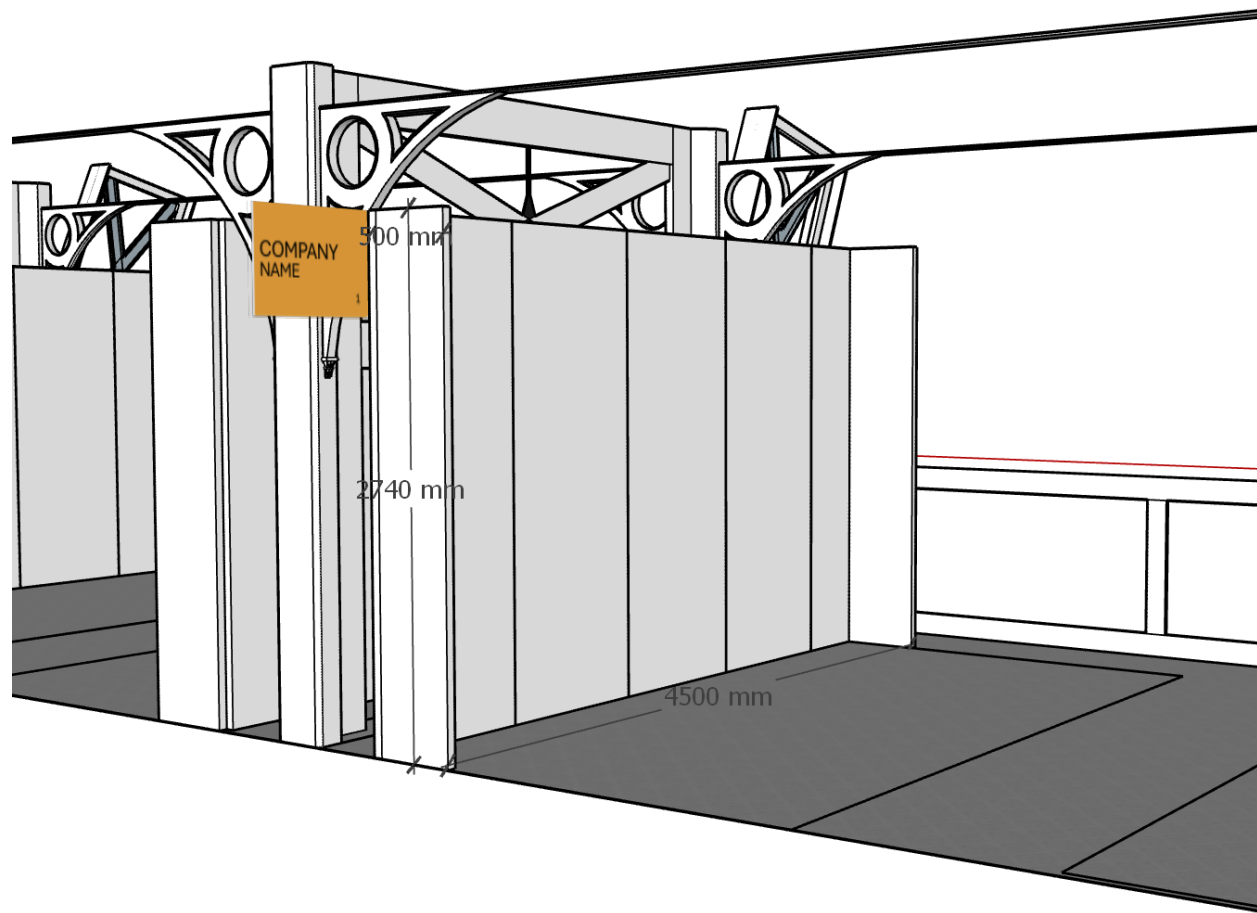

NOTE: Check your contract

Gallery Bays

Working Dimensions Within Gallery Bay Stands

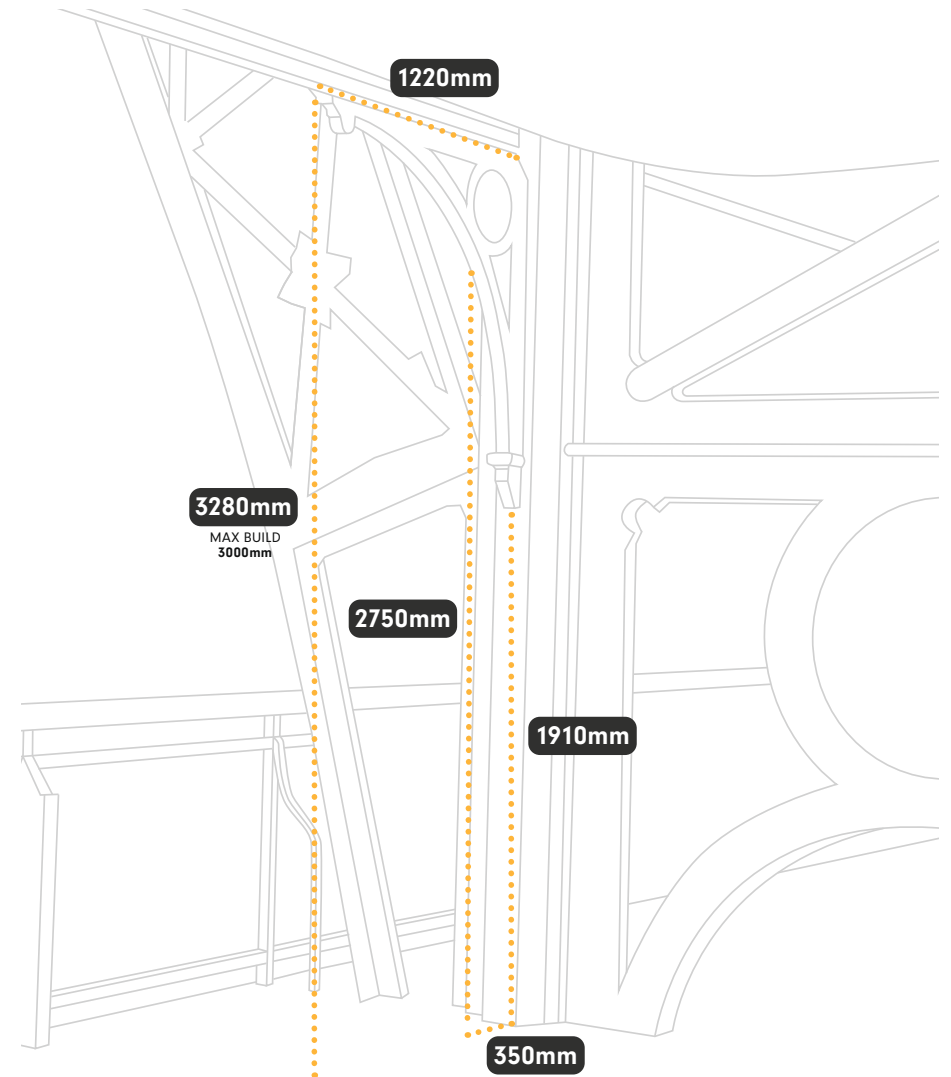

Gallery Bays

Ironwork Location Within Bay



Gallery Bay Ironwork located in each corner of the Gallery Bay. Panels to be cut down in each corner to fit under these areas (see example below).



Decorative Zone

The following pages pertain to stands within the Decorative and Design Hall (Shell Scheme stands with an D prefix)

OPEN THREE SIDES

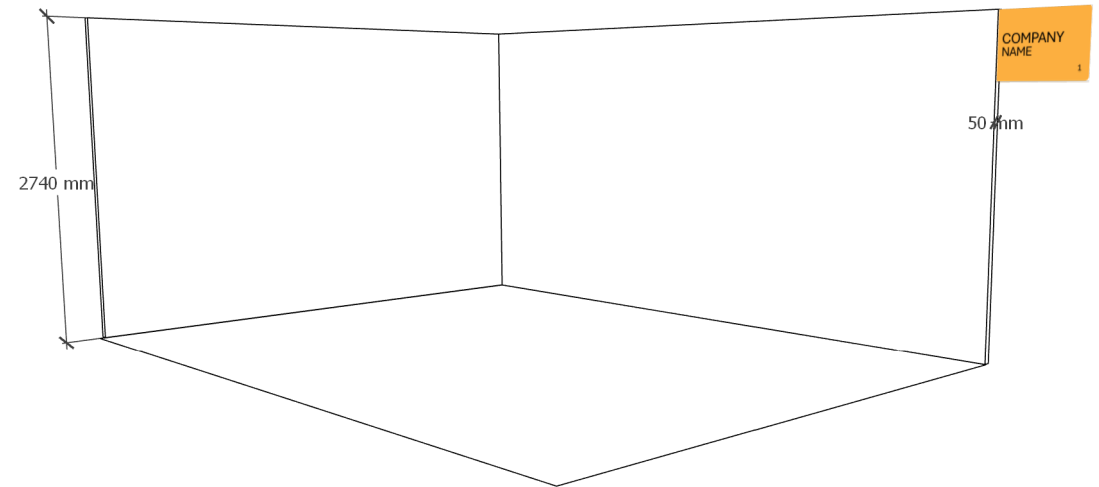
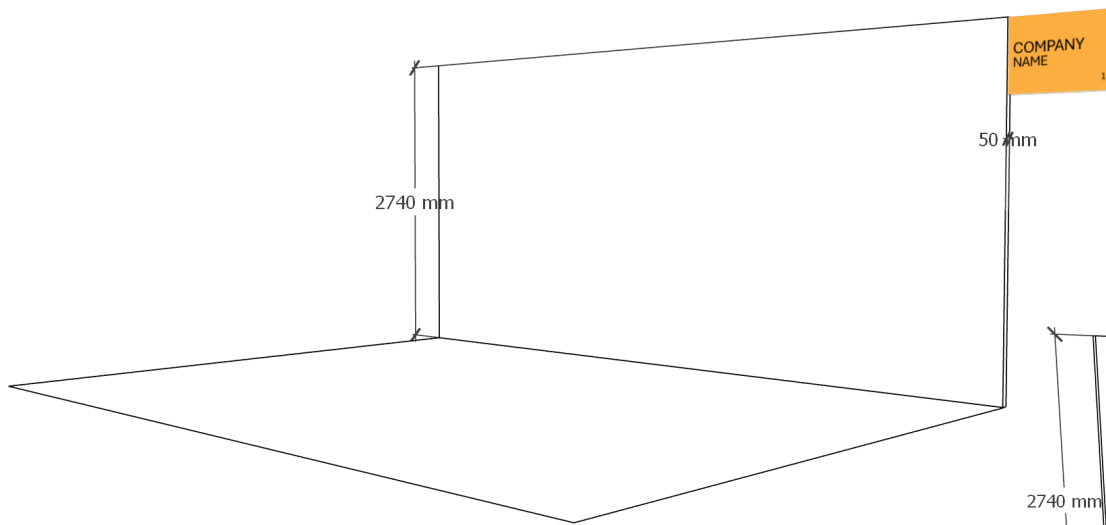

OPEN TWO SIDES

NOTE: Check your contract for your stand dimensions

Perimeter Stands

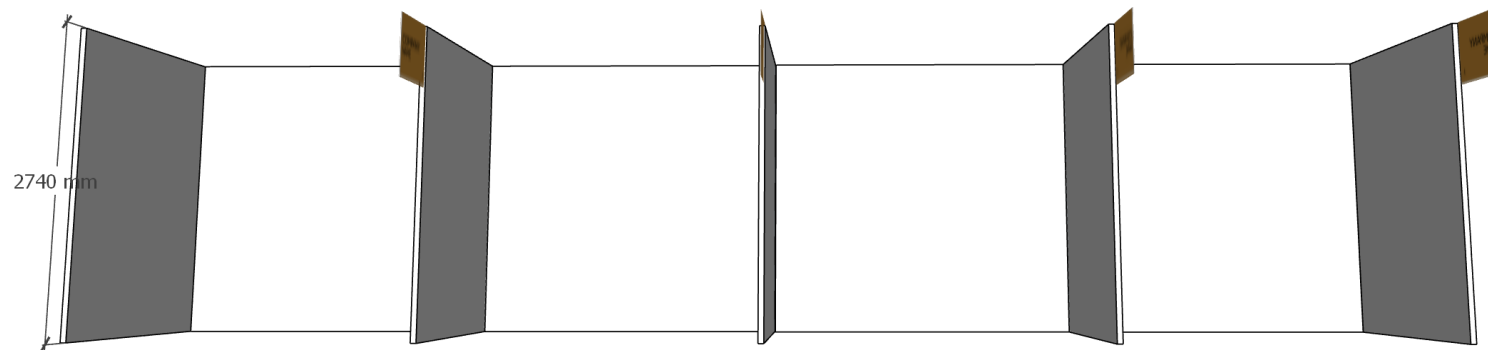
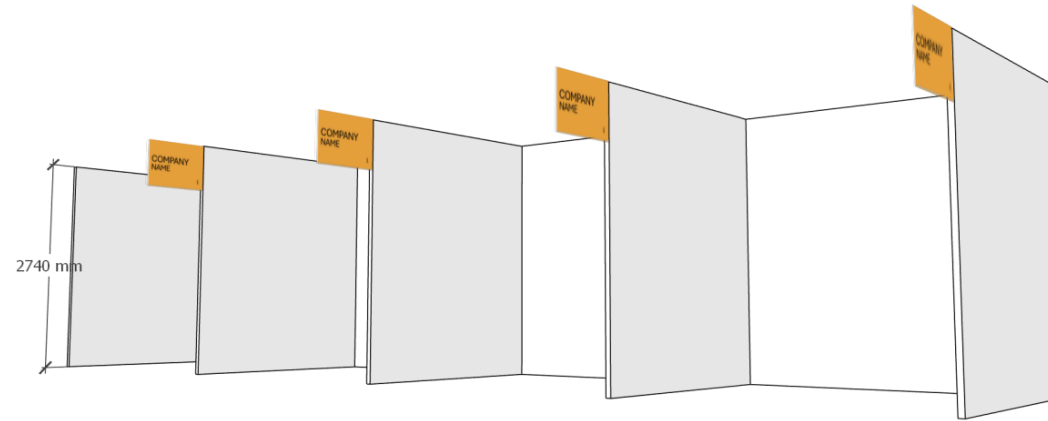

NOTE: Check your contract for your stand dimensions

Stands with columns

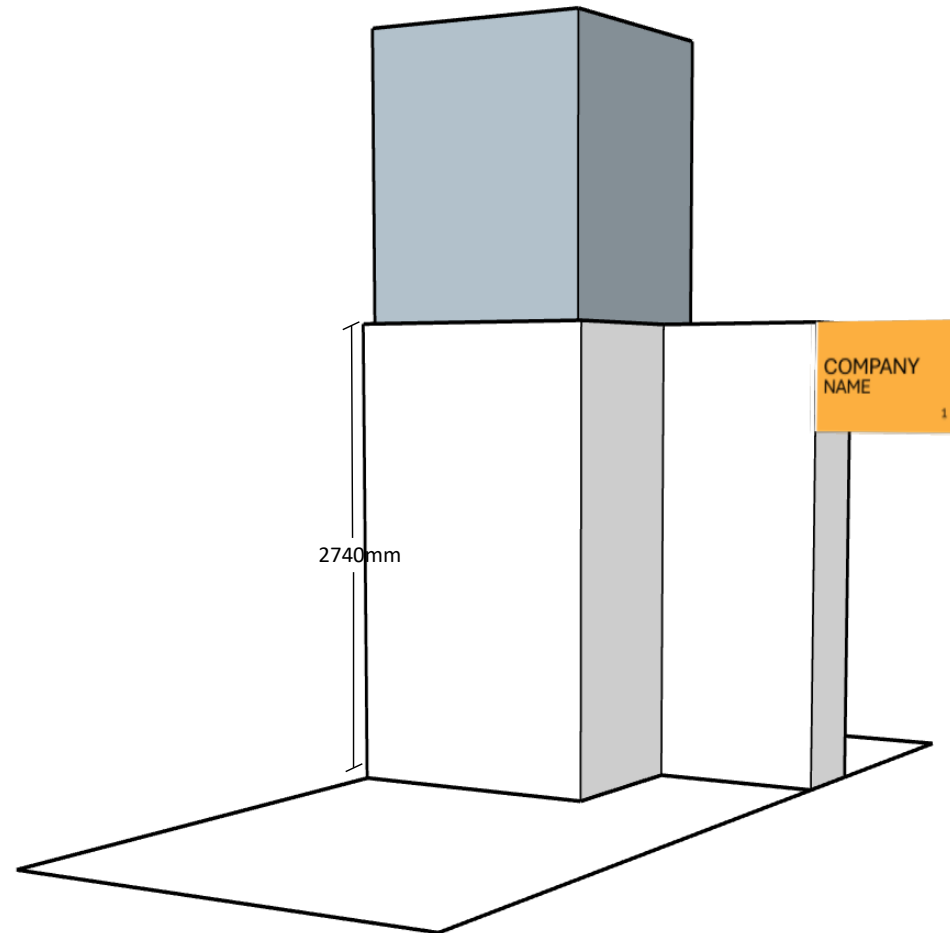

NOTE: Check your contract for your stand dimensions

Technical Zone

The following pages pertain to stands within the
Technical Hall - Ground Floor

PERIMETER STANDS T1 - T7 & T16 - T32

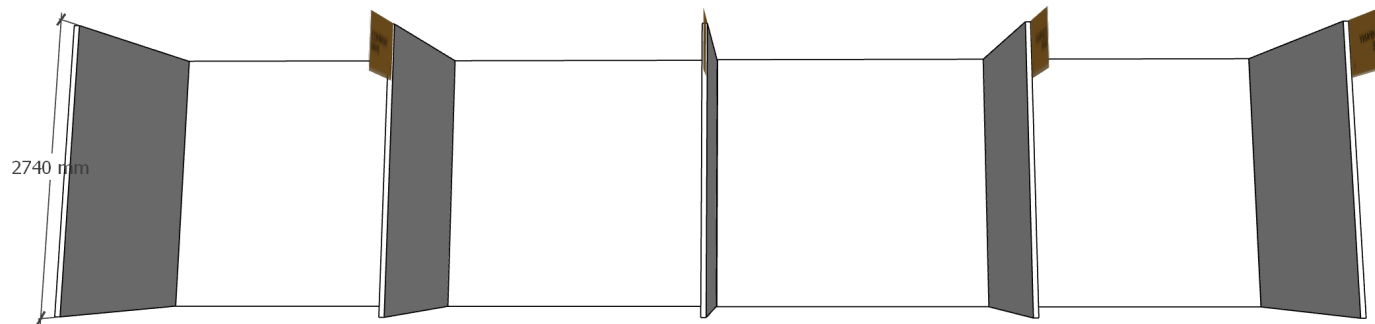
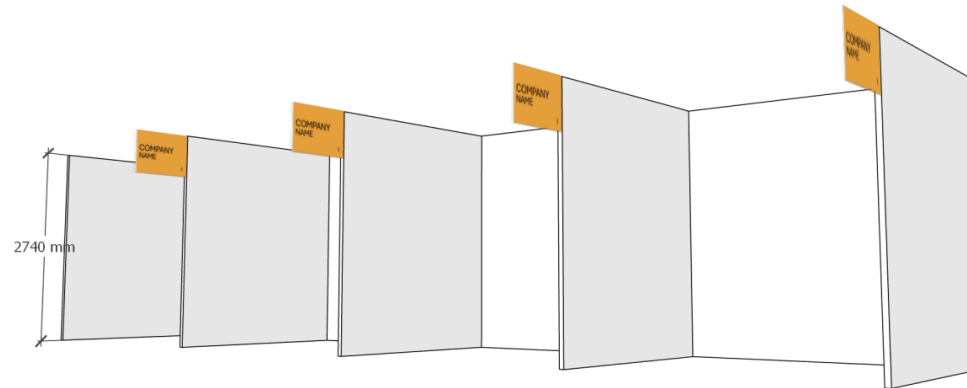

Please note the height of the shell scheme for your stand is **2.75M**

Technical Zone

The following pages pertain to stands within the
Technical Hall - Ground Floor

CENTRAL STANDS

T8 - T15

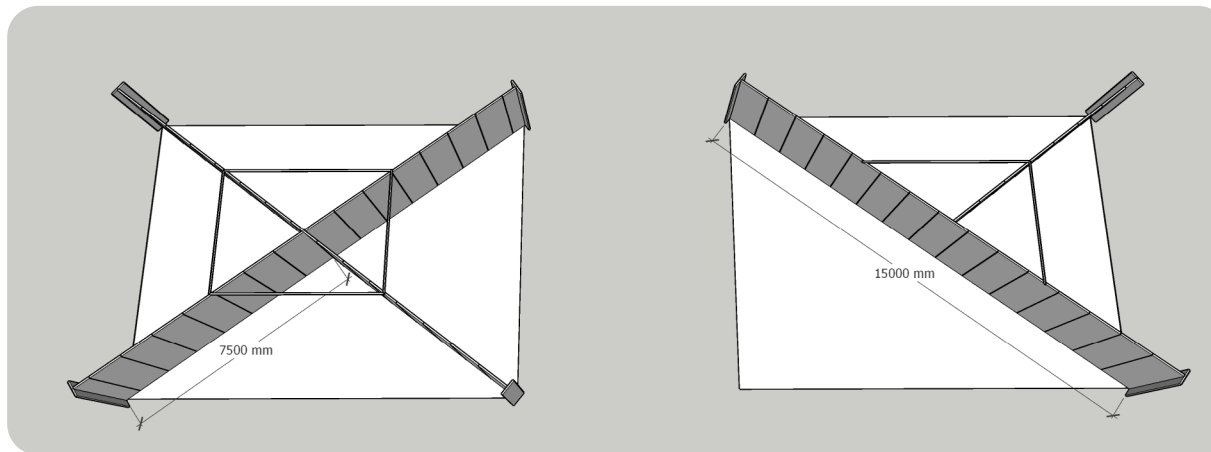
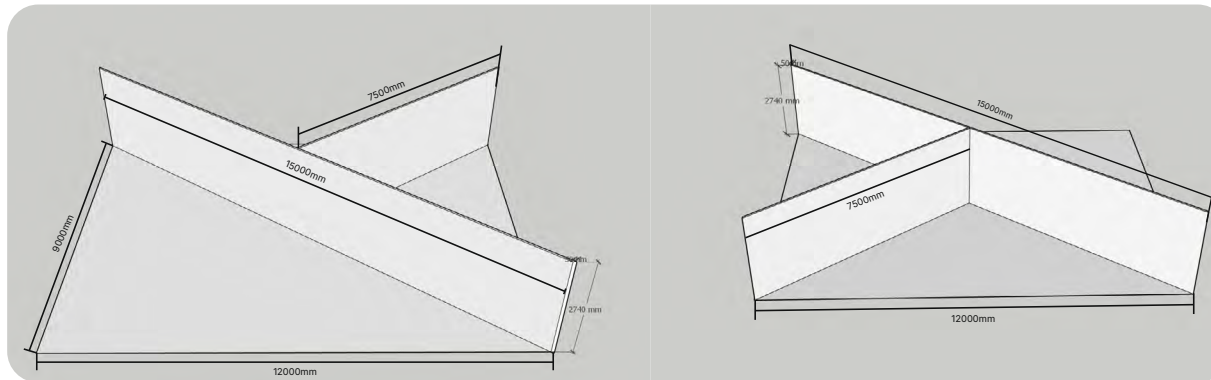

The T8-T15 stands will include **0.5m** returns at each end.

Technical Zone

The following pages pertain to stands within the
Technical Hall - Atrium Level

PERIMETER STANDS

T33 - T56

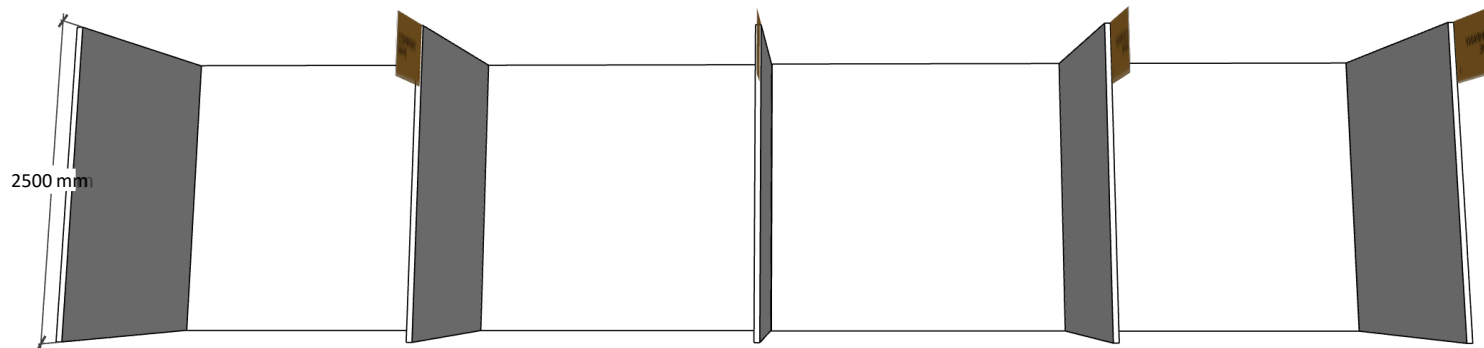
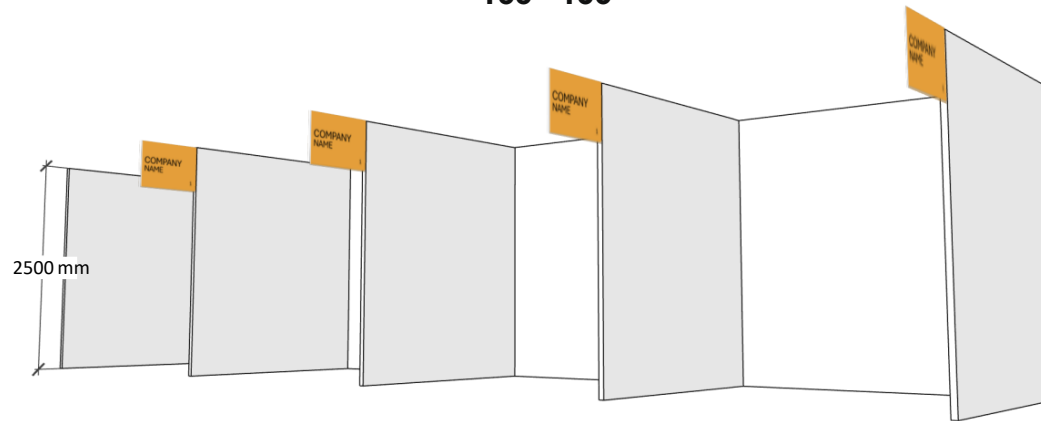

Please note the height of the shell scheme for your stand is **2.5M**

LiGHT25

[d]arc media

[d]arc media has an intimate knowledge of the lighting specification market, publishing magazines and online content as well as organising dedicated events targeted at lighting designers, architects, interior designers and specifiers.

arc and darc magazines are the leading international publications for architectural and decorative lighting specification.

[d]arc awards is the only peer-to-peer awards programme for the lighting design profession since its inaugural event in 2015.

[d]arc sessions is a new networking event bringing suppliers and specifiers together in the relaxed surroundings of international resorts.

LiGHT builds on the success of the much-loved ARC Show, which ran from 2004 to 2009 at the Business Design Centre. LiGHT is a new offering for lighting design built on [d]arc media's knowledge and experience of the lighting specification market.

Contact

For more information about the opportunities available please get in touch on the details below:

Sales Manager

John-Paul Etchells
jp.etchells@mondiale.co.uk

lightexpo.london